

» The Ergonomic

ELTRONO® ERGO offers even more ergonomic features and is especially developed for users that are spending many hours without interruption in front of monitors.

The easy and quick »Ergo-Tilt™«, enables the table top as well as the monitor shelf to tilt from 0 to 15 degrees in order to provide the best possible working position.

This feature alleviates the pressure on the body and reduces stress related disorders.

- + WORK SURFACE, DIVIDED IN TWO PARTS
- + TILTABLE MAIN WORK SURFACE
- + MOUSE PAD, EMBEDDED IN WORK SURFACE
- + MOTOR CONTROL - COMFORT
- + CABLE BOX, MOUNTED UNDER THE TABLE TOP
- + HEIGHT ADJUSTABLE



» ERGO

» ELTRONO® ERGO

The Ergonomic

FEATURES

STANDARD

- + Motorized height adjustment (for sitting and standing)
- + Work surface dimensions: 175 × 80 cm or 175 × 100 cm
- + Work surface, divided in two parts
- + 1 large work surface with motorized »Ergo-Tilt™« adjustment
- + 1 smaller surface, non tilting (on the left side)
- + Monitor rail
- + Motor control – comfort – with digital Touchscreen panel
- + Mousepad, embedded in work surface
- + Cable box
- + 7 power outlets

OPTIONAL

- + Footrest
- + CPU holder
- + Monitor pole(s)
- + Monitor holder(s) (VESA)
- + USB-Hub with 3 ports
- + Lowered screen (40 cm) to protect from insight
- + Memory function with presets

TECHNICAL SPECIFICATIONS

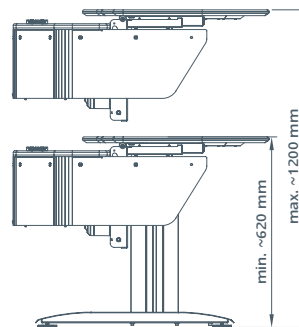
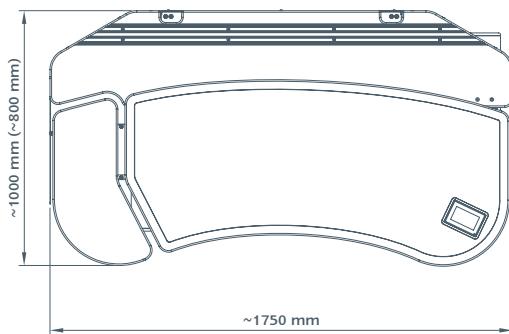

- + **AN ERGONOMICALLY DESIGNED WORKPLACE INCREASES THE EFFICIENCY AND PRODUCTIVITY AND REDUCES STRESS RELATED PROBLEMS AND FATIGUE.**



In all images ELTRONO® ERGO is equipped with options.

ELTRONO®

PLANILUX®

ELTRONO® A PLANILUX® Trademark.

Phone.: +49 (0) 29 02 · 97 13-0
Fax: +49 (0) 29 02 · 97 13-88
info@planilux.com
www.planilux.com

GERÄTEBAU
Felix Schulte GmbH & Co. KG
Rangstraße 46-48
D-59581 Warstein